

The SpeedTouch™ and VLAN bridging

Author: Bert Bertels

Date: March 2005

Version: v1.0

Abstract: This application note provides technical information on how the SpeedTouch™ can be integrated in various scenarios where VLAN frames have to be bridged between the local Ethernet segment and the DSL line, on which an Ethernet based connection model is used.

Applicability: This application note applies to all SpeedTouch™ Business DSL Routers Release R5.3.0.

Updates: THOMSON continuously develops new solutions, but is also committed to improve its existing products.

For more information on THOMSON's latest technological innovations, documents and software releases, visit us at:

<http://www.speedtouch.com>

Contents

1	Introduction.....	3
----------	--------------------------	----------

2	VLAN Transparent forwarding	4
2.1	Scenario overview.....	4
2.2	Practical realisation.....	5

3	Traffic classification on VLAN ID.....	7
3.1	Scenario overview.....	7
3.2	Practical realisation.....	8

4	Traffic classification by priority	13
4.1	Scenario overview.....	13
4.2	Practical Realisation for priority mapping to one PVC.....	16
4.3	Practical Realisation for PVC multiplexing by priority	19

1 INTRODUCTION

Bridged VLAN definition

This document will explain the configuration of the SpeedTouch™ device in Bridged Virtual Local Area Network (VLAN) scenarios.

- ▶ Bridged means that the packets will be forwarded between the local Ethernet segment (LAN) and the WAN Ethernet segment (PVCs on which RFC1483B encapsulation is used) on link layer. So the SpeedTouch™ does not terminate nor route the received packets.
- ▶ VLAN indicates that the packets that have to be forwarded are residing in different VLANs. This implies that all Ethernet packets will contain a 802.1q VLAN ID and optionally an 802.1p priority indication. Communication between the different VLANs is not allowed on link layer. Only routers can make connections between different VLANs, as if the networks would exist on physically separated Ethernet segments.

Scenario overview

3 different scenarios will be discussed in this application note:

- ▶ Complete VLAN transparency, forward/bridge all packets to a defined PVC.
- ▶ Classify traffic on VLAN ID and forward/bridge to the appropriate PVC.
- ▶ Classify traffic on a priority indication and forward/bridge to the appropriate PVC.

In following sections we will describe how the SpeedTouch™ has to be configured for each scenario.



The focus of the configuration descriptions will always be on upstream (LAN to WAN) traffic, as for these packets the classification comes in place. All configurations are of course also correctly handling the downstream traffic. If applicable, notes will be given on the downstream traffic.

2 VLAN TRANSPARENT FORWARDING

2.1 Scenario overview

Introduction

In this scenario the SpeedTouch™ is intended to transparently forward all VLAN tagged packets between the local segment and the PVC.

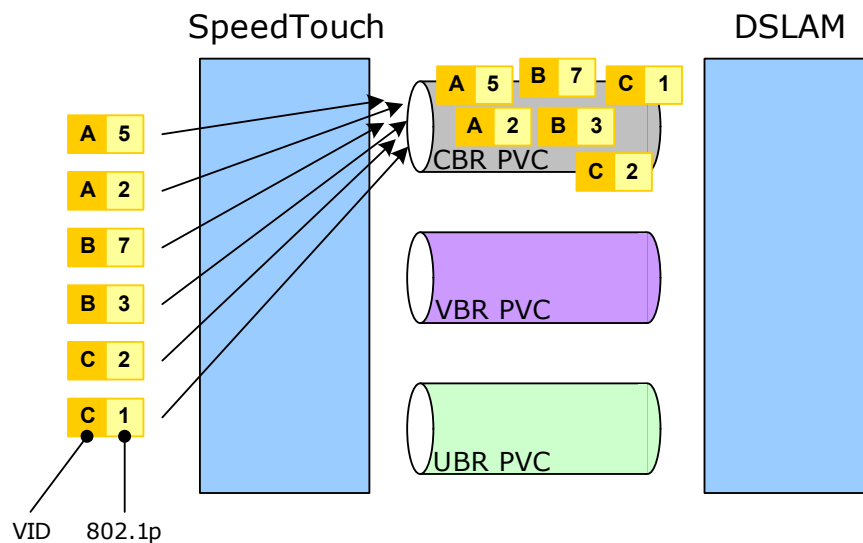

Figure 1: VLAN transparent forwarding

Technically this means that all incoming packets on the LAN-interface have to be transparently forwarded to a defined PVC on the DSL line. What the value of the VLAN ID (VID) or the priority indication is, should not influence the result. From forwarding point of view, the type of PVC (UBR, VBR or CBR) is in this basic configuration irrelevant. The PVC that all traffic has to be forwarded to is chosen at configuration time.

2.2 Practical realisation

Configuration overview

Following configuration-steps have to be performed to enable the SpeedTouch™ in this scenario:

- 1** Define which PVC to be used by configuring an ATM interface.
- 2** Connect this ATM interface to the Bridge.
- 3** Save the configuration.

In current scenario we will connect ATM PVC 0/35 to the local Ethernet segment via the embedded SpeedTouch™ bridge.

Configure an ATM interface

Execute following CLI command to create a phonebook entry for the PVC to be used:

```
:atm phonebook add name=phone_MyPVC1 addr=0.35
```

Execute following CLI commands to create, configure and connect an ATM interface on this phonebook entry:

```
:atm ifadd intf=atm_MyPVC1
:atm ifconfig intf=atm_MyPVC1 dest=phone_MyPVC1 encaps=llc u1p=mac
:atm ifattach intf=atm_MyPVC1
```

Configure a bridge interface

Execute following CLI command to connect the ATM interface to the Ethernet bridge

```
:eth bridge ifadd intf=bridge_MyPVC1
:eth bridge ifconfig intf=bridge_MyPVC1 dest=atm_MyPVC1
:eth bridge ifattach atm_MyPVC1
```

Bridge VLAN properties

As packets coming in on the SpeedTouch™ will have a VLAN header, it is required to explicitly configure that the SpeedTouch™ bridge should not be VLAN aware. If this is not done you will have to define all the VLANs that have to pass through the SpeedTouch™, as otherwise unknown VLANs will be dropped.

Execute following CLI command to check the current status of the SpeedTouch™ bridge:

```
=>:eth bridge config
Ageing : 300
Filter : no_WAN_broadcast
VLAN : disabled
=>
```

If needed, execute following CLI command to disable the VLAN awareness of the SpeedTouch™ bridge:

```
:eth bridge config vlan=disabled
```

Save the configuration

Execute following CLI command to make your changes permanent:

```
:saveall
```

Expected result

All packets arriving on the LAN port will be forwarded on the configured PVC. The same is true for traffic arriving on the SpeedTouch™ via the DSL line: it will be forwarded on the Local Ethernet segment.

Whether there is a VLAN tag on the packet or not is irrelevant for current scenario. All packets are forwarded in both directions.

3 TRAFFIC CLASSIFICATION ON VLAN ID

3.1 Scenario overview

Introduction

In this scenario the SpeedTouch™ is intended to classify the traffic based on VLAN ID. Per VID it has to be configurable on which PVC the packets have to be forwarded. Or rather, per PVC it has to be configurable of which VLAN(s) it is a member.

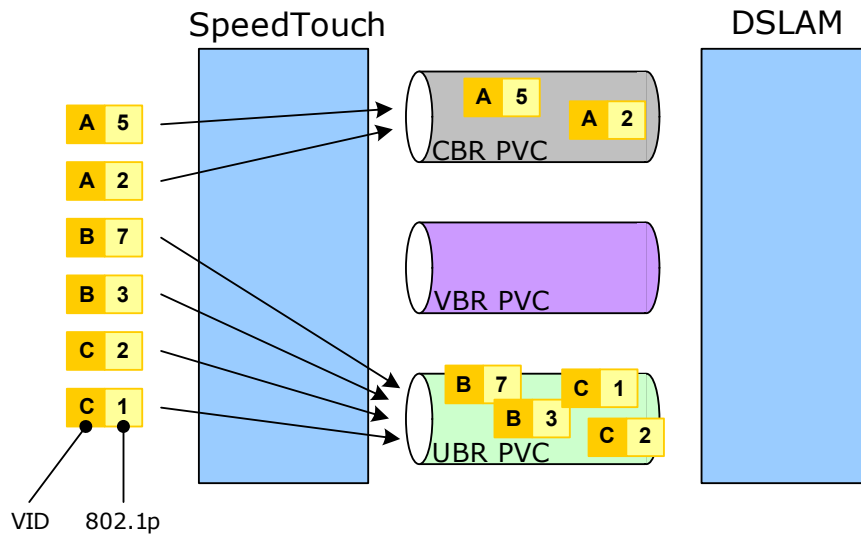

Figure 2: Traffic classification on VLAN ID

Technically this means that several VLANs will exist on the SpeedTouch™, and the bridging functionality of the SpeedTouch™ will be fully VLAN aware. Packets coming in on the LAN interface will be checked on VLAN ID, and will only be forwarded on interfaces (PVCs in this case) that are member of that VLAN.



When packets arrive on an interface with a VLAN ID of which this interface is not member, they will be forwarded anyway. For example, if in the above schema a packet with VLAN ID A would arrive on the SpeedTouch™ via the UBR PVC, the packet will be forwarded to the LAN (and possibly the CBR PVC if the destination MAC-address is not in the learning table yet).

How to get control on these and other unexpected packets is described in section “ Optional incoming traffic validation” on page 12.

3.2 Practical realisation

Configuration overview

Following configuration-steps have to be performed to enable the SpeedTouch™ in this scenario:

- 1** Define which PVCs will be used by configuring an ATM interface for each one of them.
- 2** Define the VLANs that will be used (the VID's the SpeedTouch™ has to handle).
- 3** Connect the ATM interfaces to the Bridge.
- 4** Define which interfaces are part of which VLAN.
- 5** Optionally enable traffic validation features on an interface to control unexpected packets.

After these steps, packets arriving on the SpeedTouch™ will be checked for their VLAN ID, and will be only sent out on bridge-ports which are member of that VLAN.

Configure the ATM interfaces

Execute following CLI commands to create a phonebook entry for the PVC to be used:

```
:atm phonebook add name=phone_MyUBR addr=0.35  
:atm phonebook add name=phone_MyVBR addr=0.36  
:atm phonebook add name=phone_MyCBR addr=0.37
```

Execute following CLI commands to configure ATM interfaces based on the phonebook entries:

```
:atm ifadd intf=atm_MyUBR  
:atm ifconfig intf=atm_MyUBR dest=phone_MyUBR encaps=llc ulp=mac  
:atm ifattach intf=atm_MyUBR  
  
:atm ifadd intf=atm_MyVBR  
:atm ifconfig intf=atm_MyVBR dest=phone_MyVBR encaps=llc ulp=mac  
:atm ifattach intf=atm_MyVBR  
  
:atm ifadd intf=atm_MyCBR  
:atm ifconfig intf=atm_MyCBR dest=phone_MyCBR encaps=llc ulp=mac  
:atm ifattach intf=atm_MyCBR
```

Define ATM QoS

If it is required for the scenario, specific ATM Quality of Service (QoS) profiles have to be configured and assigned to the ATM interfaces. When ATM QoS is enabled, the SpeedTouch™ will perform upstream traffic shaping to make the traffic streams conform the QoS set in the rest of the network.

As ATM QoS is not relevant for this scenario, we will skip it here.

A detailed description of how to configure ATM QoS is available on “ Define ATM QoS” on page 21.

Make the SpeedTouch™ VLAN aware



The SpeedTouch™ also supports the Integrated Local Management Interface (ILMI), used to automatically configure ATM interfaces. When ILMI is enabled in the DSL network, the Central Office (CO) will send QoS configuration parameters to the SpeedTouch™. Upon reception of these parameters, the ATM interfaces will be automatically updated with the new ATM QoS settings. For more information on how to enable ILMI, see the SpeedTouch™ ST620 R5.3.0 CLI Guide

By default the SpeedTouch™ Ethernet bridge does not take VLAN tags into account. This means that all packets will be transparently forwarded, as described in chapter “2 VLAN Transparent forwarding” on page 4.

Execute following CLI command to check the current status of the SpeedTouch™ bridge:

```
=>:eth bridge config
Ageing : 300
Filter : no_WAN_broadcast
VLAN   : disabled
=>
```

Execute following CLI command to make the SpeedTouch™ VLAN aware:

```
:eth bridge config vlan=enabled
```



From this moment on, all Ethernet packets arriving on the SpeedTouch™ with a VLAN tag, will not be forwarded anymore if there are no interfaces defined that are member of this VLAN!

Define the VLANs

Before we can assign interfaces to certain VLANs, we will have to configure which VLANs will be used. By this configuration a logical name is associated with the effective VID that will be in the VLAN header of the packet.

Execute following CLI commands to define the VLANs to be used

```
:eth vlan add name=MyVLAN_A vid=10
:eth vlan add name=MyVLAN_B vid=20
:eth vlan add name=MyVLAN_C vid=30
```

Execute following CLI command to retrieve a listing of the configured VLANs:

```
=>:eth vlan list
Vid      Name
----      -
1         default
10        MyVLAN_A
20        MyVLAN_B
30        MyVLAN_C
=>
```



As it can be seen in the listing, the SpeedTouch™ by default makes use of VID 1. Be aware of this when you are using VID 1 in your VLAN implementation.

Configure the bridge interfaces

Execute following CLI commands to connect the ATM interfaces to the bridge:

```
:eth bridge ifadd intf=bridge_MyUBR
:eth bridge ifconfig intf=bridge_MyUBR dest=atm_MyUBR
:eth bridge ifattach intf=bridge_MyUBR

:eth bridge ifadd intf=bridge_MyVBR
:eth bridge ifconfig intf=bridge_MyVBR dest=atm_MyVBR
:eth bridge ifattach intf=bridge_MyVBR

:eth bridge ifadd intf=bridge_MyCBR
:eth bridge ifconfig intf=bridge_MyCBR dest=atm_MyCBR
:eth bridge ifattach intf=bridge_MyCBR
```

Optionally, the ':eth bridge ifconfig' command can be extended with some parameters to refine the VLAN configuration. These are described in the last section of this chapter on page 12.

Assign local interfaces to VLANs

Make sure the LAN-ports that will be used are member of each VLAN they have to accept packets from. In this example we only enable Ethernet-port 4 to receive VLAN tagged packets from the LAN. The 'untagged' parameter has to be set to 'disabled' to avoid that the VLAN-header is stripped of when the packets are sent out on the interface.

Execute following CLI commands to put Ethernet port 4 in all 3 defined VLANs:

```
:eth bridge vlan ifadd name=MyVLAN_A intf=ethport4 untagged=disabled
:eth bridge vlan ifadd name=MyVLAN_B intf=ethport4 untagged=disabled
:eth bridge vlan ifadd name=MyVLAN_C intf=ethport4 untagged=disabled

:eth bridge vlan ifdelete name=default intf=ethport4
```



By removing the interface from the 'default' VLAN, IP connectivity with the SpeedTouch™ is lost via that Ethernet interface. This includes all access to configuration interfaces!

Assign WAN interfaces to VLANs

Also define for the WAN side bridge interfaces the VLAN they are member of. Do this by moving each ATM based bridge interface to the VLAN(s) that it should be member of. The 'untagged' parameter has to be set to 'disabled' to avoid that the VLAN-header is stripped of when the packets are sent out on the interface.

```
:eth bridge vlan ifadd name=MyVLAN_A intf=bridge_MyCBR untagged=disabled
:eth bridge vlan ifdelete name=default intf=bridge_MyCBR

:eth bridge vlan ifadd name=MyVLAN_B intf=bridge_MyUBR untagged=disabled
:eth bridge vlan ifdelete name=default intf=bridge_MyUBR

:eth bridge vlan ifadd name=MyVLAN_C intf=bridge_MyUBR untagged=disabled
:eth bridge vlan ifdelete name=default intf=bridge_MyUBR
```



An interface always has to be added to a specific VLAN before it can be removed from the default VLAN. The purpose is that an interface always will exist in at least one VLAN.

Save the configuration

To make your changes permanent enter following command:

```
:saveall
```

Result

Execute following CLI command to retrieve an overview of the population of the different VLANs:

```
=>:eth bridge vlan iflist

Vid      Name      Bridge interfaces (* = untagged)
---      -
1        default   OBC*, ethport1*, ethport2*, ethport3*
10       MyVLAN_A  ethport4, bridge_MyCBR
20       MyVLAN_B  ethport4, bridge_MyUBR
30       MyVLAN_C  ethport4, bridge_MyUBR
=>
```

From the table above it can be derived that packets with VID 10 (representing VLAN A) will only be transmitted on the CBR PVC, and packets with VID 20 or 30 will be transmitted on the UBR PVC. No packets will be forwarded on the VBR PVC.

Also here it is visible that IP connectivity to the SpeedTouch™ itself is only possible from the interfaces that are in the default VLAN, thus not from Ethernet port 4. The reason is that the SpeedTouch™ IP host is connected to the bridge via the OBC interface, which is only in the default VLAN, with VID 1. If IP connectivity to the SpeedTouch™ from other VLANs is required, the OBC interface has to be added (by the **:eth bridge vlan ifadd** command) to those VLANs also.

Optional incoming traffic validation

With current configuration there is no explicit regulation what has to happen with unexpected packets that arrive on any of the VLAN bridge interfaces of the SpeedTouch™. Examples of these unexpected packets are untagged packets or tagged packets arriving on an incorrect interface.

Following parameters exist to control these unexpected packets and are configurable per bridge interface (when the bridge is in VLAN mode):

- ▶ `vlan = {ConfiguredVLAN}`

When setting the parameter 'vlan = MyVLAN_x', all untagged packets arriving on that interface will be handled as if they were tagged with MyVLAN_x. This option is mutually exclusive with the `acceptvlanonly` parameter.

- ▶ `ingressfiltering = {enabled | disabled}`

When enabled, the ingress filter will block packets that are not tagged with a VID of which the interface is member. By default this parameter is set to disabled. This means that all incoming packets are accepted, no matter what VID they have set. Of course these packets will only be sent out on interface that are member of the correct VLAN.

- ▶ `acceptvlanonly = {enabled | disabled}`

When enabled, only tagged packets will be accepted. By default this parameter is disabled which means that untagged packets will be mapped to the VLAN as defined with the 'vlan = MyVLAN_x' parameter. This parameter is mutually exclusive with the `vlan` parameter.

All parameters have to be set on each interface separately. Hereunder some configuration examples:

```
:eth bridge ifdetach intf=bridge_MyUBR
:eth bridge ifconfig intf=bridge_MyUBR vlan=MyVLAN_A
:eth bridge ifattach intf=bridge_MyUBR

:eth bridge ifdetach intf=bridge_MyVBR
:eth bridge ifconfig intf=bridge_MyVBR ingressfiltering=enabled
:eth bridge ifattach intf=bridge_MyVBR

:eth bridge ifdetach intf=bridge_MyCBR
:eth bridge ifconfig intf=bridge_MyCBR ingressfiltering=enabled acceptvlanonly=enabled
:eth bridge ifattach intf=bridge_MyCBR
```



The parameters could also be added in the configuration of the bridge interfaces as described on page 9

4 TRAFFIC CLASSIFICATION BY PRIORITY

4.1 Scenario overview

Introduction

In this configuration the SpeedTouch™ is intended to take into account a priority indication available in the protocol headers of the frames that it is bridging.

This process is based upon two steps:

- 1 Map the available priority indication of an incoming frame to an internal priority class.
- 2 Send out the frame while taking into account its internal priority class.

The classification of incoming packets can be based on:

- ▶ the VLAN user priority value (802.1p, also referred to as the VLAN p-bit),
- ▶ the IP TOS-byte for IP packets (using Precedence or DiffServe CodePoint (DSCP) notation).

When sending out the packets afterwards, the priority indication can be used to:

- ▶ Perform priority queueing on a single PVC.
- ▶ Perform traffic multiplexing over a range of PVC's.

With two possible input mappings, and two output options, this would allow us to describe a total of four different combinations. But as the input and output configuration are totally independent of each other, and transparently interchangeable, we will limit ourselves to two different scenarios.

VLAN user priority mapping to one PVC

In this first example we will bridge the incoming VLAN tagged packets to a single PVC, but taking into account the VLAN priority available in the VLAN header. This means that high priority marked packets will get priority when sending out the packets on the WAN link.

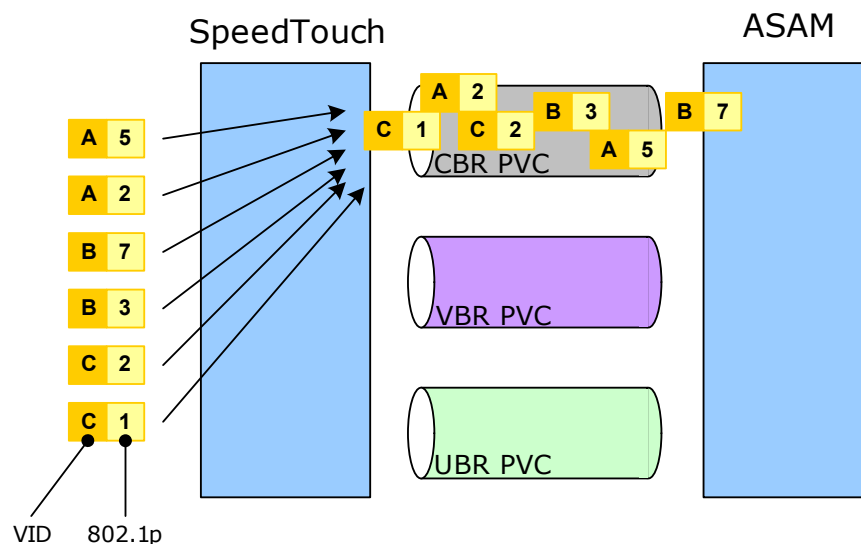

Figure 3: Traffic classification on 802.1p value to one PVC

IP TOS mapping for ATM multiplexing

The main priority indication of a frame in the bridge is the 802.1p VLAN user priority. However the SpeedTouch™ also offers the possibility to check the TOS byte for the IP packets in the frames that are bridged.

Following figure shows a second example, with the mapping of IP TOS priority towards different PVCs.

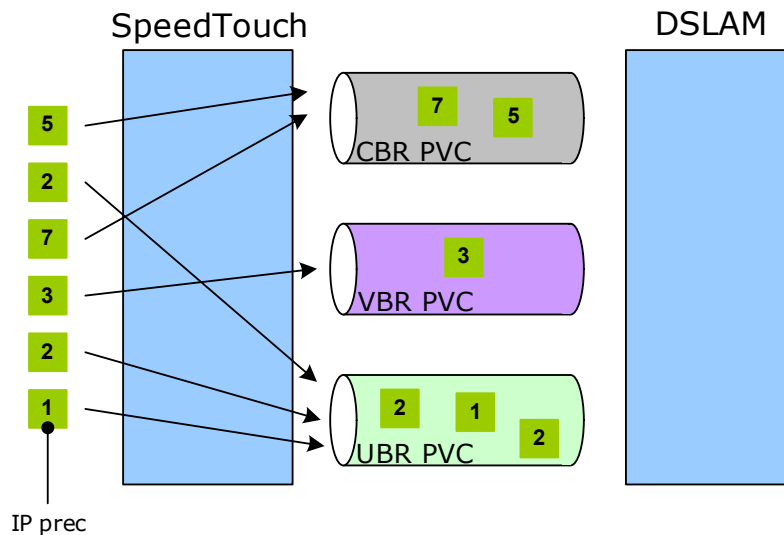

Figure 4: Traffic classification on IP TOS value to an ATM bundle

Priority classification process

When looking at priority classification technically, the priority to PVC mapping is performed in 2 steps:

- 1 The incoming frames are mapped to an internal priority class.

The SpeedTouch™ internally uses 16 priority classes. Each incoming frame will be associated with one of them, depending on its characteristics.

- 1 Frames arriving on the bridge will be checked for a link layer priority indication, for VLAN frames the 802.1p user priority indication.
- 2 If enabled, the value of the TOS byte in the IP header is checked. It is configurable whether IP precedence or DSCP notation is used in the network. When a value is found, the configuration allows to specify if the internal class has to be changed:
 - ▶ overwrite: The IP TOS priority indication will be used, over-writing the VLAN priority mapping.
 - ▶ only increase: IP TOS priority will be used if it maps to a higher value than the VLAN priority.

The table on the next page shows how the VLAN user priority indication, or the IP TOS value is mapped to an internal class. This mapping is static.

- 2 Depending on the internal priority class the frame is sent out in a certain way.
 - ▶ With a single PVC, the internal priority indication can be used to perform priority based bridging of the frames. For this the frames will be handled by the SpeedTouch™ priority queueing mechanism as in IPQoS. For more detailed information refer to the IPQoS Configuration Guide.
 - ▶ With multiple PVC's, the traffic can be multiplexed by the ATM-bundling feature. An ATM-bundle is no more than a group of ATM-interfaces (PVCs) that is representing itself as one virtual ATM interface. Inside the ATM-bundle it is possible to enable priority based multiplexing of traffic. The ATM-bundle will check the internal priority class of a frame and matches it with one of the PVCs.

SpeedTouch™ priority mapping table

Following table gives an overview of how

- ▶ incoming frames are mapped towards the SpeedTouch™ internal class,
- ▶ the internal class is mapped to a QoS queue or ATM-bundle.

In this table only two columns are configurable:

- ▶ The 802.1p mapping to internal classes can be altered on a per interface basis. It is configurable to re-order the 8 possible values by means of the “VLAN regeneration table”.
- ▶ The ATM-bundle mapping is in this table as described in scenario “ IP TOS mapping for ATM multiplexing” on page 14. By configuration you are able to change the reach of each PVC. In the table this reflects to the height of each cell (e.g. from which to which internal class interface atm_MyCBR is mapped).

802.1p value	IP Precedence	DSCP	Internal Class	QoS queue	ATM-bundle mapping	
7	6,7	CS6, CS7	15	RealTime	atm_MyCBR	
6	5	EF CS5	14			
	4	AF41 CS4	13	WFQ1		
		AF42, AF43	12			
	3	AF31 CS3	11	WFQ2		
5		AF32,AF33	10			
	2	AF21 CS2	9	WFQ3		atm_MyVBR
4		AF22, AF23	8			
	1	AF11 CS1	7	WFQ4		
3		AF12, AF13	6			
			5	Best Effort	atm_MyUBR	
0	0	CS0	4			
			3			
2			2			
			1			
1			0			

The priority order of the 802.1p values is in line with IEEE 802.1d-Annex H.

For more detailed description on everything related to IP and Quality of Service, please refer to the IPQoS Configuration Guide R5.3.0.

4.2 Practical Realisation for priority mapping to one PVC

Configuration overview

To achieve the first scenario to work, following configuration-steps have to be performed:

- ▶ Enable VLAN priority mapping for incoming frames on the LAN port.
- ▶ Define the PVC that will be used by configuring an ATM interface.
- ▶ Connect this ATM interface to the bridge.
- ▶ Enable QoS on the PVC to activate priority queuing.

Like this frames arriving on the SpeedTouch™ LAN interface, will be sent out on one PVC based on their priority indication.

Enable VLAN priority mapping

For the scenario we will only enable the mapping of the 802.1p priority indication of VLAN tagged frames to an internal priority class for Ethernet port 4.

Execute following CLI command to enable this:

```
:eth bridge ifconfig intf ethport4 prioconfig overwrite
```

Two parameters can be used in current scenario:

- ▶ prioconfig = enabled

By default the frames with 802.1p priority indication will not be mapped to an internal class of the SpeedTouch™. To enable this the 'prioconfig' parameter has to be set to 'overwrite'.

- ▶ regenprio = <string>

This parameter can be used to change the order in which the 802.1p value is mapped to a certain internal class. The default mapping can be seen in the table on page 15. If however this mapping does not fit your needs it can be reshuffled by entering the 'regenprio' parameter. If for example you wish to prioritize the 802.1p values as 0 is lowest and 7 is highest, following CLI command would be needed:

```
:eth bridge ifconfig intf ethport4 prioconfig overwrite regenprio=20134567
```

Execute following CLI command to verify the configuration of your bridge interface:

```
=>:eth bridge iflist intf ethport4

ethport4 : dest : ethif4
          Connection State: connected  Retry: 10
          Port: ethport4      PortNr: 4      PortState: forwarding  Interface: down
          Multicast filter: disabled
          VLAN: Default VLAN: default  Ingressfiltering: disabled  Acceptvlanonly: disable
d
          VLAN: Priority: overwrite  IP Prec: disabled  Priority: 0  Regen table: 01234567

          RX bytes: 0      frames: 0
          TX bytes: 0      frames: 0      dropframes: 0

=>
```

ATM interfaces

Configure a logical name for the PVC by means of a phonebook entry (VPI/VCI used are indicative):

```
:atm phonebook add name=phone_MyUBR addr=0.35
```

Configure an ATM interface based on this phonebook entry:

```
:atm ifadd intf=atm_MyUBR
:atm ifconfig intf=atm_MyUBR dest=phone_MyUBR encaps=llc ulp=mac
:atm ifattach intf=atm_MyUBR
```

Bridge VLAN properties

As packets coming in on the SpeedTouch™ will have a VLAN header, it is required to explicitly configure that the SpeedTouch™ bridge should not be VLAN aware. If this is not done you will have to define all the VLANs that have to pass through the SpeedTouch™, as otherwise unknown VLANs will be dropped.

Execute following CLI command to check the current status of the SpeedTouch™ bridge:

```
=>:eth bridge config
Ageing : 300
Filter : no_WAN_broadcast
VLAN   : disabled
=>
```

If needed, execute following CLI command to disable the VLAN awareness of the SpeedTouch™ bridge:

```
:eth bridge config vlan=disabled
```

Configure the bridge interface

Execute following CLI command to connect the ATM interface to the bridge:

```
:eth bridge ifadd intf=bridge_MyUBR  
:eth bridge ifconfig intf bridge_MyUBR  
:eth bridge ifattach intf=bridge_MyUBR
```

Enable QoS on the ATM interface:

Even in bridging mode we can make advantage of the powerful SpeedTouch™ IPQoS implementation. By enabling IPQoS on the PVC we use, we enable the packet queuing mechanism, which is active on ATM interface level. This queueing mechanism handles incoming packets according to their internal class. As we have this set, we can be treated equally as packet that is coming from the IPQoS framework.

```
:ipqos config dest phone_MyUBR state enabled
```

Save the configuration

Execute following CLI command to make your changes permanent:

```
:saveall
```

Result

At this moment all packets containing an 802.1p value will be, priority wise, bridged on one PVC.

4.3 Practical Realisation for PVC multiplexing by priority

Configuration overview

To bridge frames, multiplexed on multiple PVC's, based upon the IP TOS value of the IP header, following configuration-steps have to be performed:

- ▶ Enable IP TOS priority mapping for incoming frames on the LAN port,
- ▶ Define which PVCs will be used by configuring an ATM interface for each one of them
- ▶ Define ATM QoS
- ▶ Create an ATM Bundle to perform priority multiplexing towards different PVC's
- ▶ Connect this ATM bundle to the bridge

Like this frames arriving on the SpeedTouch™ LAN interface, will be sent out on different PVCs based on the priority indication in their IP header.

Enable IP TOS priority mapping

When enabling IP TOS priority classification, you can choose for 2 different approaches.

- ▶ Solely take the IP priority into account (overruling the 802.1p priority that is set before the IP check)
- ▶ Take into account the highest priority indication of both 802.1p and IP TOS

Solely taking IP priority into account actually means that the initial 802.1p mapping will be overwritten.

Execute following CLI command to enable pure IP classification (prioconfig parameter) on Ethernet port 4, defining that we use IP Precedence TOS marking (ipprec parameter).

```
:eth bridge ifconfig intf=ethport4 prioconfig=overwrite ipprec=precedence
```

After this, the SpeedTouch™ is configured to classify incoming frames on Ethernet port 4 solely by the IP TOS value (as shown in "Figure 4: Traffic classification on IP TOS value to an ATM bundle" on page 14).

Execute following CLI command to verify the configuration of the priority mapping:

```
=>:eth bridge iflist intf ethport4
ethport4: dest : ethif4
          Connection State: connected   Retry: 10
          Port: ethport4      PortNr: 4      PortState: forwarding   Interface: down
          Multicast filter: disabled
          VLAN: Default VLAN: default   Ingressfiltering: disabled   Acceptvlanonly: disabled
          VLAN: Priority: overwrite IP Prec: precedence Priority: 0   Regen table: 01234567
          RX bytes: 0          frames: 0
          TX bytes: 0          frames: 0          dropframes: 0
```

Another example could be to check the IP priority indication (this time using the DSCP definition), but only increase the internal class if the IP priority indicates a higher priority than the 802.1p indication. Following CLI command would configure this:

```
:eth bridge ifconfig intf=ethport4 prioconfig=increase ipprec=dscp
```



When the packet to be bridged is not an IP packet, the default internal class (4) will be used.



For more detailed description on everything related to IP and Quality of Service, please refer to the IPQoS Configuration Guide R5.3.0.

Configure the ATM interfaces

Execute following CLI commands to create a phonebook entry for the PVC to be used:

```
:atm phonebook add name=phone_MyUBR addr=0.35  
:atm phonebook add name=phone_MyVBR addr=0.36  
:atm phonebook add name=phone_MyCBR addr=0.37
```

Execute following CLI commands to configure ATM interfaces based on the phonebook entries:

```
:atm ifadd intf=atm_MyUBR  
:atm ifconfig intf=atm_MyUBR dest=phone_MyUBR encaps=llc ulp=mac  
:atm ifattach intf=atm_MyUBR  
  
:atm ifadd intf=atm_MyVBR  
:atm ifconfig intf=atm_MyVBR dest=phone_MyVBR encaps=llc ulp=mac  
:atm ifattach intf=atm_MyVBR  
  
:atm ifadd intf=atm_MyCBR  
:atm ifconfig intf=atm_MyCBR dest=phone_MyCBR encaps=llc ulp=mac  
:atm ifattach intf=atm_MyCBR
```

Define ATM QoS

If it is required for the scenario, specific ATM Quality of Service (QoS) profiles have to be configured and assigned to the ATM interfaces. When ATM QoS is enabled, the SpeedTouch™ will perform upstream traffic shaping to make the traffic streams conform the QoS set in the rest of the network.



The SpeedTouch™ also supports the Integrated Local Management Interface (ILMI), used to automatically configure ATM interfaces. When ILMI is enabled in the DSL network, the DSLAM will send QoS configuration parameters to the SpeedTouch™. Upon reception of these parameters, the ATM interfaces will be automatically updated with the new ATM QoS settings. For more information on how to enable ILMI, see the SpeedTouch™ ST620 R5.3.0 CLI Guide

Proceed as follows to manually configure ATM QoS on the ATM interfaces:

- 1** Create Connection Traffic Descriptors (ctdadd) for the different types of ATM QoS classes you wish to use. In this example we will need UBR, CBR and VBR.

Execute following CLI commands to define the 3 traffic descriptors:

```
:atm qosbook ctdadd name=ubr conformance=UBR peakrate=s
:atm qosbook ctdadd name=vbr-nrt conformance=VBR peakrate=x sustrate=y, maxburst=z
:atm qosbook ctdadd name=cbr conformance=CBR peakrate=q
```



The values for peakrate (peak cell rate, kbps - 0 means linerate), sustrate (sustainable rate, kpbs) and maxburst (maximum burst size, bytes) have to be defined in line with the ATM QoS defined on the DSL line.

- 2** Create ATM QoS profiles, called qosbook entries, which define what Connection Traffic Descriptors have to be used for upstream (txctd) and downstream (rxctd) traffic. These qosbook entries will be used on a per ATM interface basis.

Execute following CLI commands to create the qosbook entries:

```
:atm qosbook add name=qos_MyUBR txctd=ubr rxctd=ubr
:atm qosbook add name=qos_MyVBR txctd=vbr-nrt rxctd=vbr-nrt
:atm qosbook add name=qos_MyCBR txctd=cbr rxctd=cbr
```



Although downstream Connection Traffic Descriptors can be set, no active traffic policing will be performed. This feature might become available in future releases.

- 3** Assign the ATM QoS profiles to their respective ATM interfaces.

Execute following CLI commands to assign a qosbook entry to each ATM interface:

```
:atm ifconfig intf=atm_MyUBR qos=qos_MyUBR
:atm ifconfig intf=atm_MyVBR qos=qos_MyVBR
:atm ifconfig intf=atm_MyCBR qos=qos_MyCBR
```

Create the ATM bundle

Configure an ATM bundle, that is enabled to perform a priority-mapping towards the ATM-interfaces it contains.

Execute following CLI commands to create the ATM bundle:

```
:atm bundle add name=atm_MyBundle
:atm bundle config name=atm_MyBundle policy=priority
```

Execute following CLI commands to define which ATM interfaces will be part of the ATM bundle.

```
:atm bundle ifadd name=atm_MyBundle intf=atm_MyUBR
:atm bundle ifadd name=atm_MyBundle intf=atm_MyVBR
:atm bundle ifadd name=atm_MyBundle intf=atm_MyCBR

:atm bundle ifconfig name=atm_MyBundle intf=atm_MyUBR state=enabled low=0 high=5
:atm bundle ifconfig name=atm_MyBundle intf=atm_MyVBR state=enabled low=6 high=9
:atm bundle ifconfig name=atm_MyBundle intf=atm_MyCBR state=enabled low=10 high=15
```

The 'low' and 'high' value of the ifconfig command are the parameters that define what range of the internal priority classes are related to which PVC.

Execute following CLI command to attach the ATM-bundle:

```
:atm bundle attach name atm_MyBundle
```

Execute following CLI command to verify your ATM-bundle configuration.

```
=>:atm bundle list

atm_MyBundle: Connection state : connected
      Retry: 10                               Policy: priority  Propagate: disabled
      TX requested bytes: 0                     requested frames: 0
      TX bytes: 0                               frames: 0
      RX bytes: 0                               frames: 0
      Index: 0  Interface: atm_MyUBR           State: enabled   Selector: 0-5
                TX bytes: 0                     frames: 0
                RX bytes: 0                     frames: 0
                RX discarded bytes: 0           discarded frames: 0
                Disconnects: 0
      Index: 1  Interface: atm_MyVBR           State: enabled   Selector: 6-9
                TX bytes: 0                     frames: 0
                RX bytes: 0                     frames: 0
                RX discarded bytes: 0           discarded frames: 0
                Disconnects: 0
      Index: 2  Interface: atm_MyCBR           State: enabled   Selector: 10-15
                TX bytes: 0                     frames: 0
                RX bytes: 0                     frames: 0
                RX discarded bytes: 0           discarded frames: 0
                Disconnects: 0

=>
```

Bridge VLAN properties

As packets coming in on the SpeedTouch™ will have a VLAN header, it is required to explicitly configure that the SpeedTouch™ bridge should not be VLAN aware. If this is not done you will have to define all the VLANs that have to pass through the CPE, as unknown VLANs will be dropped.

Execute following CLI command to check the current status of the SpeedTouch™ bridge:

```
=>:eth bridge config
Ageing : 300
Filter : no_WAN_broadcast
VLAN   : disabled
=>
```

Execute following CLI command to disable the VLAN awareness of the SpeedTouch™ bridge:

```
:eth bridge config vlan=disabled
```

Configure the Bridge interface

Execute following CLI command to create the bridge interface:

```
:eth bridge ifadd intf=bridge_MyUBR
:eth bridge ifconfig intf=bridge_MyUBR dst=atm_MyBundle
:eth bridge ifattach intf=bridge_MyUBR
```

Save the configuration

Execute following CLI command to make your changes permanent:

```
:saveall
```

Result

At this moment all packets will be mapped onto one of the PVC's in the ATM-bundle, based upon the priority indication of the IP header.

Visit us at:

www.speedtouch.com

Acknowledgements

All Colleagues for sharing their knowledge.

Coordinates

THOMSON Telecom Belgium
Prins Boudewijnlaan 47
B-2650 Edegem
Belgium
E-mail: documentation.speedtouch@thomson.net

speedtouch™

Copyright

©2005 THOMSON. All rights reserved.

The content of this document is furnished for informational use only, may be subject to change without notice, and should not be construed as a commitment by THOMSON. THOMSON assumes no responsibility or liability for any errors or inaccuracies that may appear in this document. The information contained in this document represents the current view of THOMSON on the issues discussed as of the date of publication. Because THOMSON must respond to changing market conditions, it should not be interpreted to be a commitment on the part of THOMSON, and THOMSON cannot guarantee the accuracy of any information presented after the date of publication. This document is for informational purposes only. THOMSON MAKES NO WARRANTIES, EXPRESS OR IMPLIED, AS TO THE INFORMATION IN THIS DOCUMENT.

The names of actual companies and products mentioned herein may be the trademarks of their respective owners.